

# PILOT TYPE VACUUM REGULATORS

## NVR200, NVRA200



- Uses the vacuum pilot method (diaphragm indirect operation type).
- Achieves superior pressure stability in the face of fluctuating flow rates.

### NVR□200

- Small change in the set pressure when flow rate increases.

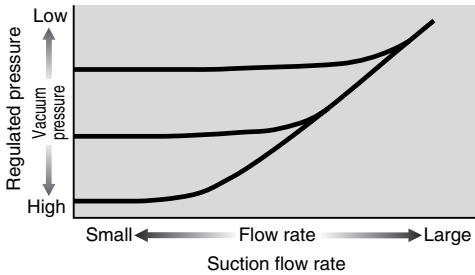

### Conventional product

- Large change in the set pressure when flow rate increases.

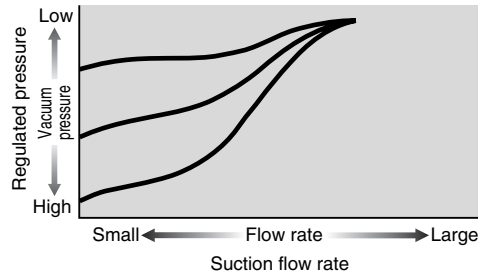

※These graphs are image diagrams. Results vary depending on the performance and conditions of the vacuum pump used.

- Use of the indirect operation type achieves lightweight (0.20kg [0.44lb.]) and compact (50×40×109cm [1.969×1.575×4.291in.]) design with a large flow rate.  
Suction flow rate MAX.200 ℓ/min [7.06ft<sup>3</sup>/min.] (ANR)<sup>Note</sup> Note: Varies depending on conditions.
- External pilot type (NVRA200) for cases where pressure regulation operations are difficult such as inside panel applications.  
Enables remote operation by using the vacuum regulator for pilot pressure regulation.
- Select from two piping port diameters (Rc1/8, Rc1/4).

## Application Examples

### ① NVR200

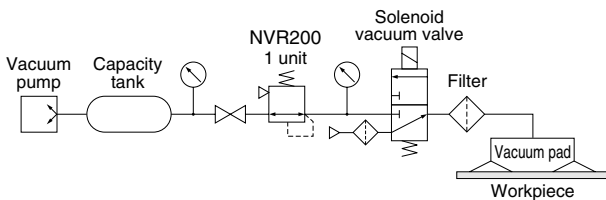

### ③ Vacuum pressure regulation using vacuum packaging

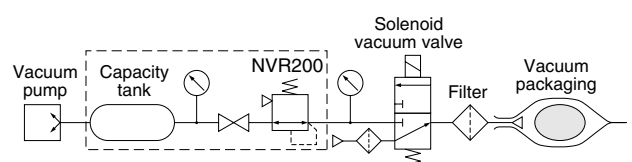

### ② Multiple vacuum pressure units required

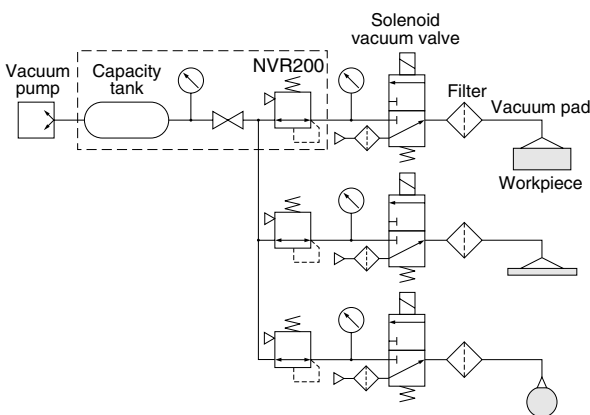

### ④ Vacuum pressure regulation using vacuum plate

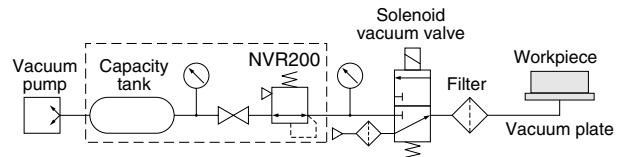

### ● NVRA200 (External pilot type)

When using NVRA200, the boxed part of the circuit above is instead configured as shown to the right.

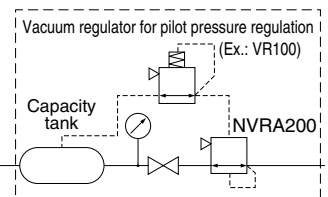

# Symbols

## Internal pilot

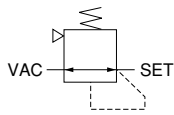

## External pilot

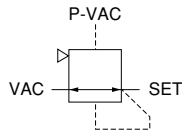

# Specifications

Item	Model	NVR200		NVRA200	
Pilot specification		Internal vacuum pilot type		External vacuum pilot type	
Port size	Rc	1/8	1/4	1/8	1/4
Media		Air			
Set pressure range <sup>Note1</sup>	kPa [in.Hg]	- 2.5 ~ - 95 [- 0.74 ~ - 28.06]			
Set pressure sensitivity <sup>Note1</sup>	kPa [in.Hg]	0.1 [0.03]			
Repeatability <sup>Note1</sup>	% (F.S.)	2		0.6	
Proof pressure	MPa [psi.]	0.5 [73]			
Suction flow rate <sup>Note1</sup>	ℓ/min [ft <sup>3</sup> /min.] (ANR)	MAX.130 [4.59]	MAX.200 [7.06]	MAX.130 [4.59]	MAX.200 [7.06]
Operating temperature range	°C [°F]	5 ~ 60 [41 ~ 140]			
Vacuum gauge port diameter	Rc	1/4			
Mass <sup>Note2</sup>	kg [lb.]	0.20 [0.44]		0.17 [0.37]	

Notes: 1. May vary depending on conditions on the SET (pressure regulation) side and pump performance on the VAC (vacuum pump) side.  
 These figures are for the case connected to a vacuum pump with exhaust speed of 1000 ℓ/min [35.3ft<sup>3</sup>/min.] or higher, and a maximum vacuum level of - 101kPa [- 29.84in.Hg] or more. (Reference)  
 2. Excluding the option

# Order Codes

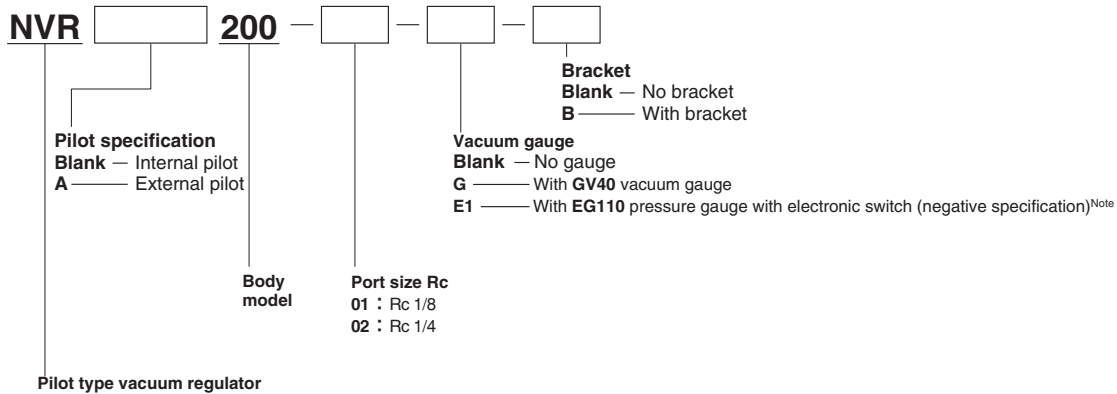

- Order Code only for vacuum gauge  
**GV-40** (standard)
- Order code for pressure gauge with electronic switch (negative pressure specification)<sup>Note</sup>  
**EG110**

Note: For specifications, dimensions, and handling of the pressure gauge with electronic switch, see p.177, pressure gauge with electronic switch.

# Inner Construction and Major Parts

## Internal Pilot NVR200

### Major Parts and Materials

Parts	Materials
Body	Aluminum die-casting
Bonnet	Plastic
Knob	Plastic
Pilot diaphragm	Synthetic rubber
Main valve diaphragm	
Pilot valve	Synthetic rubber + Aluminum alloy
Valve	Brass
Relief valve	Aluminum alloy
Relief plug	Plastic

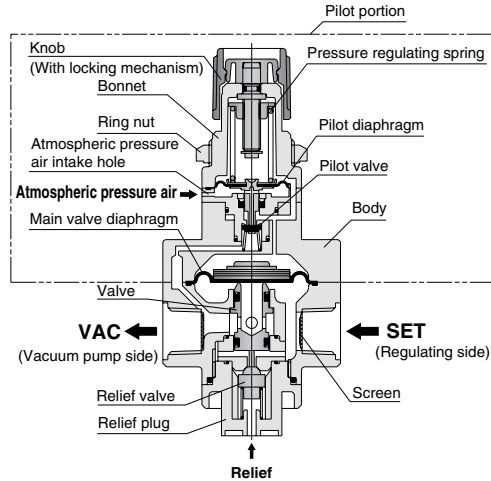

## External Pilot NVRA200

### Major Parts and Materials

Parts	Materials
Body	Aluminum die-casting
Main valve diaphragm	Synthetic rubber
Valve	Brass
Relief valve	Aluminum alloy
Relief plug	Plastic

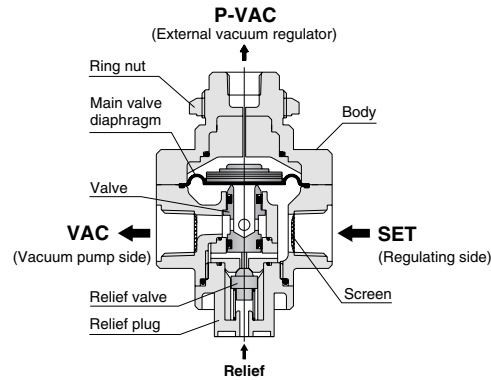

### Configuration and Features of Vacuum Pilot Type (Diaphragm Indirect Operation Type) Refer to NVR200 inner construction

When rotating the knob to regulate the vacuum pressure, the pressure regulation spring compression force does not directly operate on the main valve diaphragm in this configuration. Instead, pressure on the upper part of the body (the pilot) is regulated, so that only a constantly maintained vacuum pilot pressure operates on the main valve diaphragm. As a result, even if the flow rate is increased when required by conditions, it eliminates the effect of fluctuations in the pressure regulation spring force on the main valve diaphragm operation stroke, and achieves a stable flow rate characteristic that shows little change in set vacuum pressure due to a rising flow rate.

In addition, use of the vacuum pilot type eliminates the need to set the pressure regulation spring to match the size of the main valve diaphragm, to achieve a more compact, more lightweight body.

## Flow Rate Characteristics

### Internal pilot NVR200-01

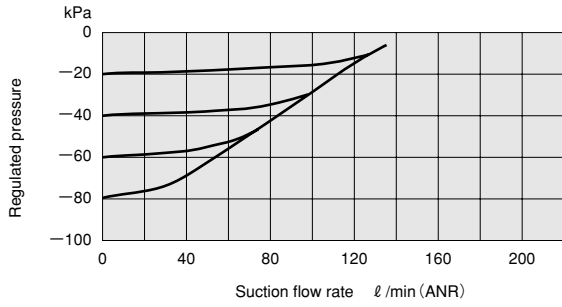

### NVR200-02

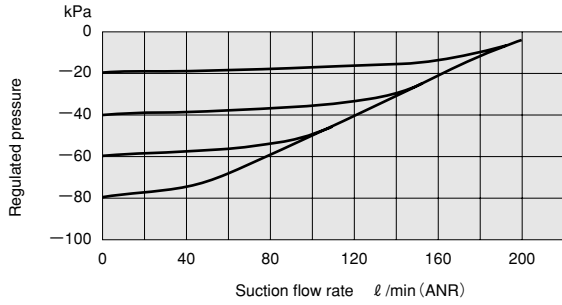

### External pilot NVRA200-01

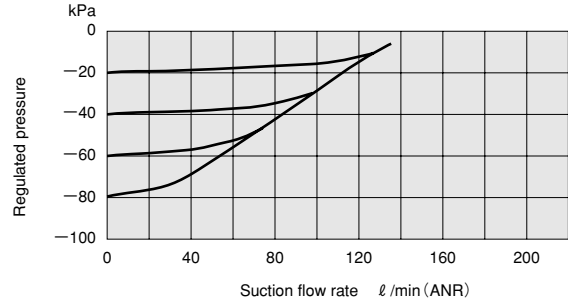

### NVRA200-02

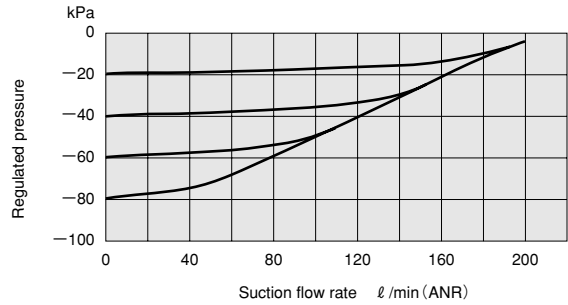

1 l/min [0.353 ft<sup>3</sup>/min.] — 100kPa = -29.54in.Hg

Remark: Characteristics when connected to a vacuum pump with exhaust speed of 1000 l/min [35.3 ft<sup>3</sup>/min.] or higher, and a maximum vacuum level of -101kPa [-29.84in.Hg] or more.

## Pressure Characteristics

### Internal pilot NVR200-01, -02

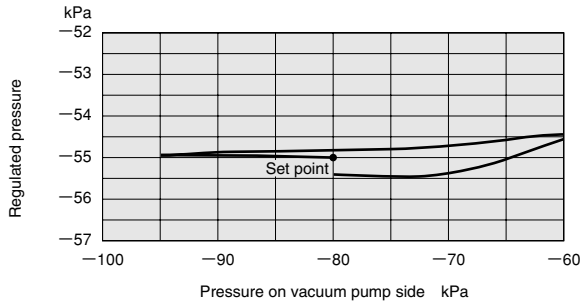

### External pilot NVRA200-01, -02

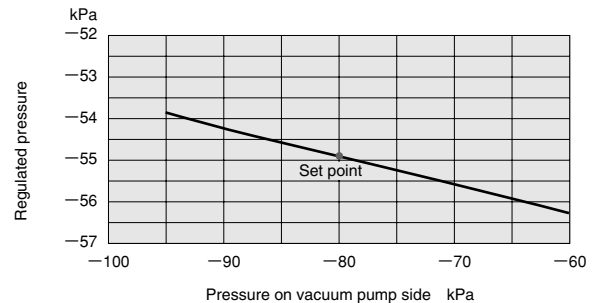

Remark: The external pilot type is affected by the characteristics of the pilot pressure vacuum regulator.

— 100kPa = -29.54in.Hg

## Dimensions of Pilot Type Vacuum Regulators mm [in.]

### Internal pilot NVR200

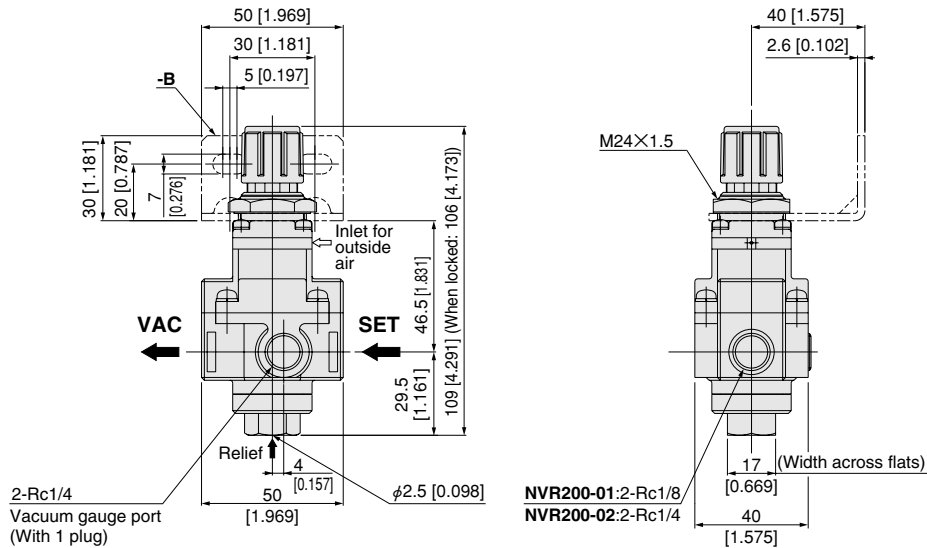

### External pilot NVRA200

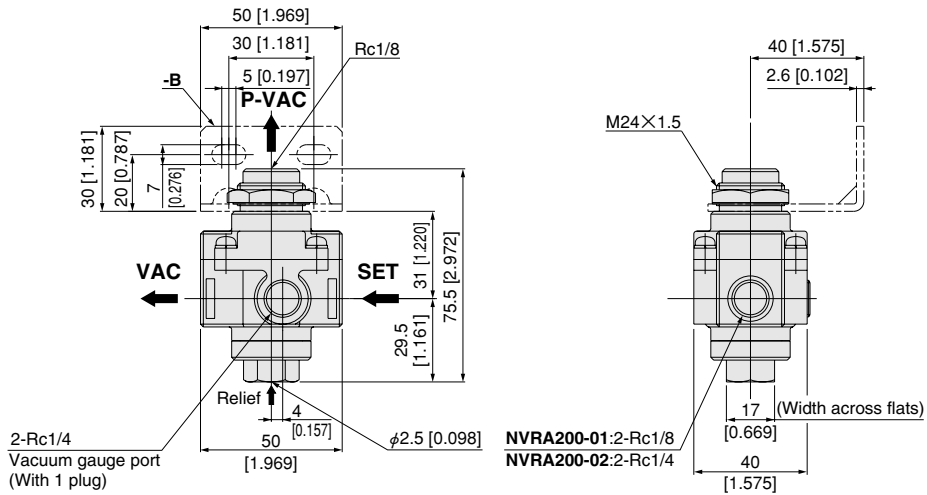

## Dimensions of Vacuum Gauge and Pressure Gauge with Electronic Switches mm [in.]

### GV-40

● Panel mount vacuum gauge<sup>Note1</sup>

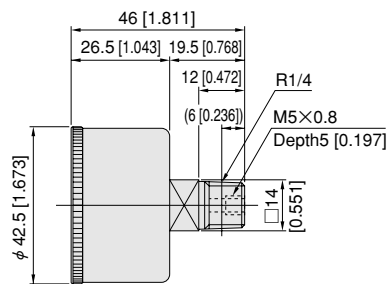
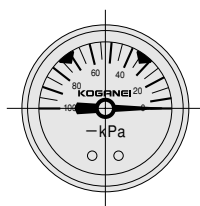

### EG110<sup>Note2</sup>

### GPV-40

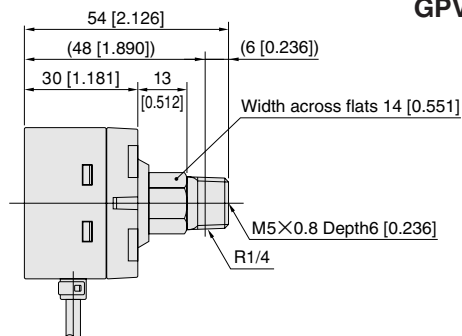
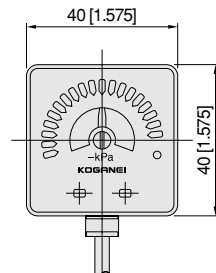

Notes: 1. The panel mounting type is available for vacuum gauge. See p.175.

2: For specifications, dimensions, and handling of the pressure gauge with electronic switch, see p.177.



## Pressure regulation

1. When regulating the pressure, connect a vacuum gauge to the vacuum gauge connection port (Rc1/4) on the pilot type vacuum regulator.
2. Always pull the knob out firmly to perform pressure regulation, rotating it to the right (clockwise) to reduce the pressure “atmospheric pressure → vacuum pressure” and rotating it to the left (counterclockwise) to increase the pressure “vacuum pressure → atmospheric pressure.” To set the pressure, rotate it to the right “atmospheric pressure → vacuum pressure” direction. Using left rotation “vacuum pressure → atmospheric pressure” to set may result in an imprecise pressure setting. After regulating pressure, push the knob back into the body and lock it in place.



- Cautions:**
1. The vacuum regulator constantly sucks in a minute amount of atmospheric pressure air to maintain a balance. As a result, be careful to avoid blocking the body's inlet for outside air. Pressure cannot be set when the inlet hole is blocked.
  2. At the start of operations, such as when the vacuum pump operation is restarted, or when vacuum pressure fluctuations on the VAC side are large, the set pressure on the SET side may shift slightly. If precise pressure settings are required, perform the pressure regulation operation again.



## Mounting and Piping

1. If mounting the pilot type vacuum regulator as a single unit, use a bracket (optional). A ring nut can also be used for panel mounting. Do not exceed a ring nut tightening torque of 980.7N·cm [7.23ft·lbf].
2. Set the mounting position so that the knob is top. If the knob must unavoidably be mounted facing down, there may be noise from vibration. In this case, either change the setting pressure, or adjust the suction flow rate, etc.
3. Do not mount the pilot type vacuum regulator in a location where it will be directly subjected to strong shocks or vibrations.
4. Do not perform any machining on the body of the unit, etc., for mounting. Its functions could be damaged.
5. For piping to the vacuum regulator, connect so that the VAC mark is on the vacuum pump side. Piping connections on the opposite side must not be made.
6. Since performance is affected by the capacity of the vacuum pump used, take special care in selecting the vacuum pump. If the set pressure is undergoing a large change, either change the vacuum pump or change the piping. If the vacuum pump cannot be changed, install a capacity tank on the VAC side.

- Cautions:**
1. Avoid an application that involves installing a valve partway along the piping between the vacuum pump and pilot type vacuum regulator, and repeatedly switching the VAC side vacuum pressure.
  2. The pilot type vacuum regulator uses a metal seal configuration for its relief portion, which means that the SET side vacuum pressure cannot maintain the set pressure when the VAC side supply stops due to shutdown of the vacuum pump, etc. To prepare for situations where the VAC side supply has stopped while a workpiece is in being transferred using a vacuum pad, install check mechanisms along the SET side piping to prevent workpiece falls.
  3. For  $\phi 4$  [0.157in.] $\times \phi 2.5$  [0.098in.] tube, if piping using it is connected to the external pilot type (NVRA200) pilot port, we recommend the length to 5m [16.4ft.] or less. A large piping volume or piping resistance can prevent a proper pressure setting.



## General precautions

1. Always thoroughly blow off (use compressed air) the piping before plumbing. Entering chips, sealing tape, rust, etc., generated during plumbing could result in air leaks or other defective operation.
2. Use air for the media. For the use of any other media, consult us.
3. If using in locations subject to dripping water, dripping oil, etc., or to large amounts of dust, use something to cover and protect the unit.